

JFA CONNECTOR J2000 SERIES

Disconnectable Crimp style connectors

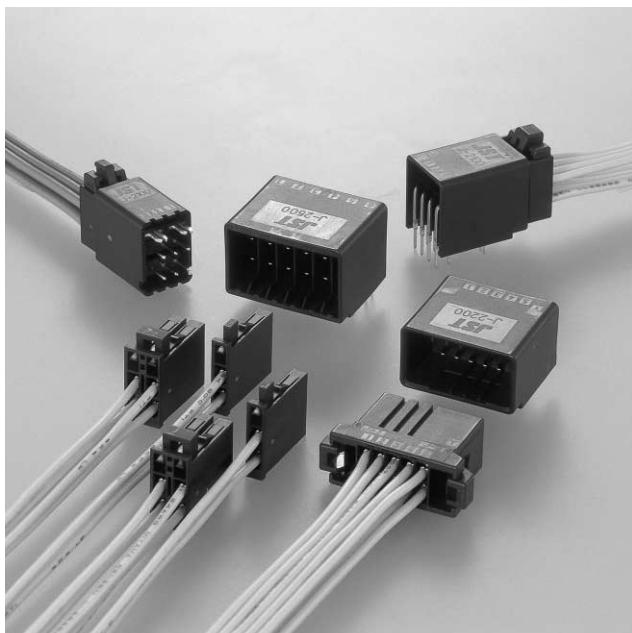

2.5mm (.098") pitch double-row connector for miniaturization of electronic equipment. Both center locking and side locking can be properly used according to a use. Receptacle contacts are designed to be common with all JFA connector J2000 series.

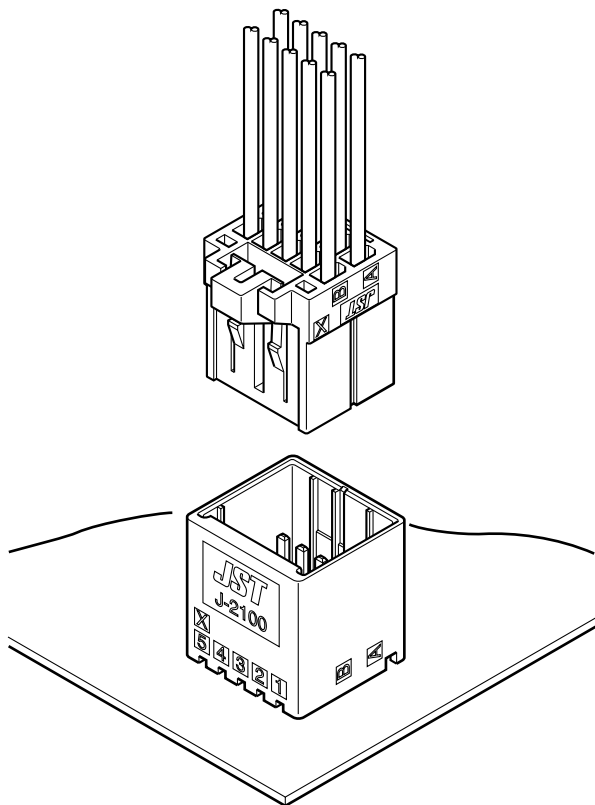

Features

• Double-spring construction

Double-spring construction realizes stable contact performance. In addition, the length of contact is shortened to miniaturize connector.

• 2 kinds of locking method

"Center locking" realizes high-density mounting on PC board, and "side locking" utilizes height direction of PC board.

• Housing lance

Housing lance assures stable assembly and smooth insertion even in thin wire.

• Clear "click feeling"

Clear feeling of click when mating connector can be realized secure engagement.

Specifications

- Current rating: 4.3A max. AC, DC (6 circuits/AWG #20)
- Voltage rating: 250V AC, DC
- Temperature range: -55°C to +105°C
(including temperature rise in applying electrical current)
- Withstanding voltage: 1,500V AC/minute
- Applicable wire: AWG #28 to #18 (0.08 to 0.75mm²)
- Applicable PC board thickness: 1.6mm (.063")
- * Contact JST if Lead-Free product is required.
- * Refer to "General Instruction and Notice when using Terminals and Connectors" at the end of this catalog.
- * Contact JST for details.

Standards

Recognized E60389

JFA CONNECTOR J2000 SERIES

List of J2000 series products

2.5mm (.098") pitch/ Voltage rating 250V AC, DC

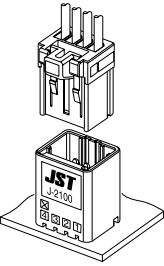
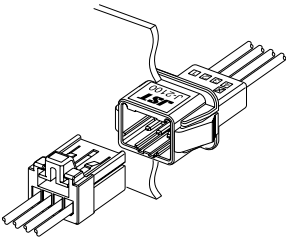
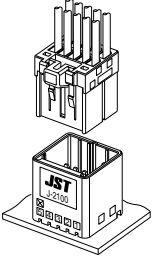
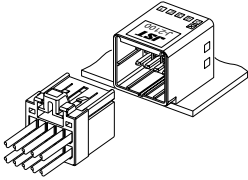
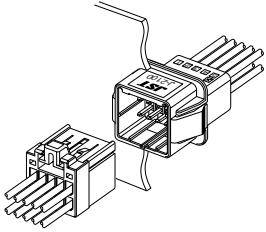
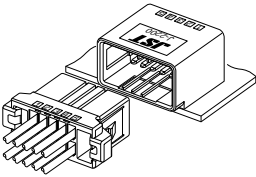
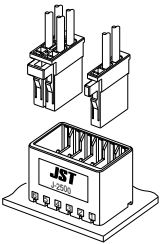
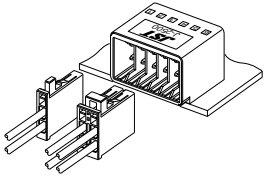
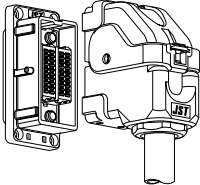
Type		Wire to Board		Wire to Wire
		Top entry type	Side entry type	Panel mounting type
Center locking type	J2100 Single-row type			
	Circuits	3, 4	Under development	4
Center locking type	J2100 Double-row type			
	Circuits	6, 8, 10, 12, 16, 20	6, 8, 10, 12, 16, 20	6, 10, 12, 16, 20
Side locking type	J2200 Double-row type			
	Circuits	Under development	10	Under development
Module type	J2500			
	Circuits	12, 20	12, 20	Under development
Metal shell type	J2900			
	Circuits			40

JFA CONNECTOR J2000 SERIES

Receptacle contact

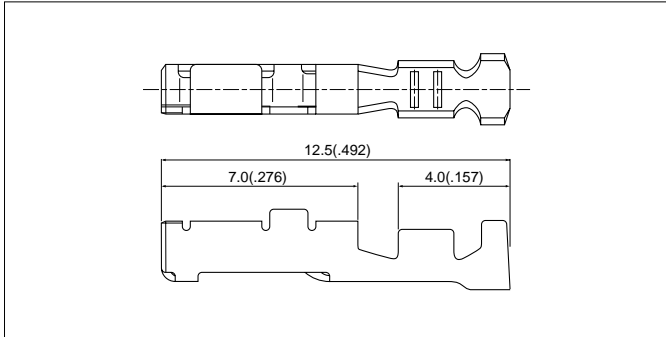

Strip form model No.	Applicable wire			Insulation O.D. mm(in.)	Q'ty /reel
	Nominal	mm ²	AWG#		
SJ2F-002GF-P1.0	S	0.08 to 0.20	28 to 24	0.8 to 1.5(.031 to .059)	6,000
SJ2F-01GF-P1.0	M	0.20 to 0.52	24 to 20	1.1 to 1.6(.043 to .063)	6,000
SJ2F-21GF-P1.0	L	0.30 to 0.75	–	1.3 to 1.9(.051 to .075)	5,000

Material and Finish

Copper alloy (superior conductivity), nickel-undercoated, selective gold-plated

Tab contact

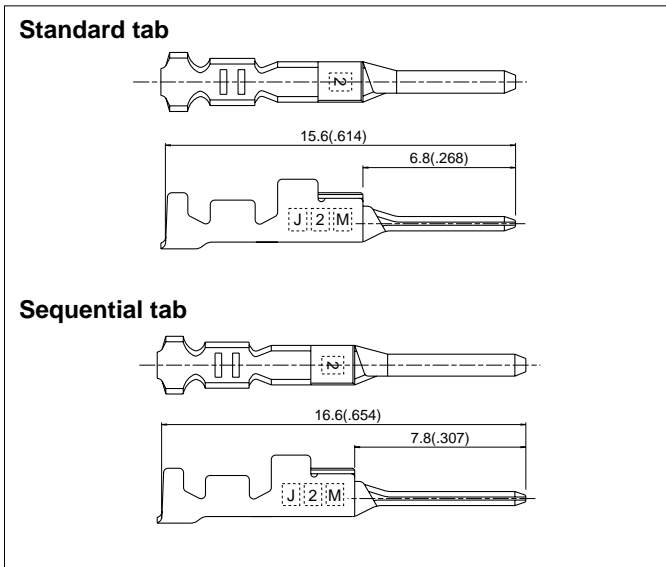

Strip form model No.	Applicable wire			Insulation O.D. mm(in.)	Q'ty /reel
	Nominal	mm ²	AWG#		
SJ2M-002GF-M1.0N	S	0.08 to 0.20	28 to 24	0.8 to 1.5(.031 to .059)	5,500
SJ2M-01GF-M1.0N	M	0.20 to 0.52	24 to 20	1.1 to 1.6(.043 to .063)	5,500
SJ2M-21GF-M1.0N	L	0.30 to 0.75	–	1.3 to 1.9(.051 to .075)	5,000
SJ2M-01GF-M1.0S	Sequential	0.20 to 0.52	24 to 20	1.1 to 1.6(.043 to .063)	5,500

Material and Finish

Copper alloy (superior conductivity), nickel-undercoated, selective gold-plated

Keying plug

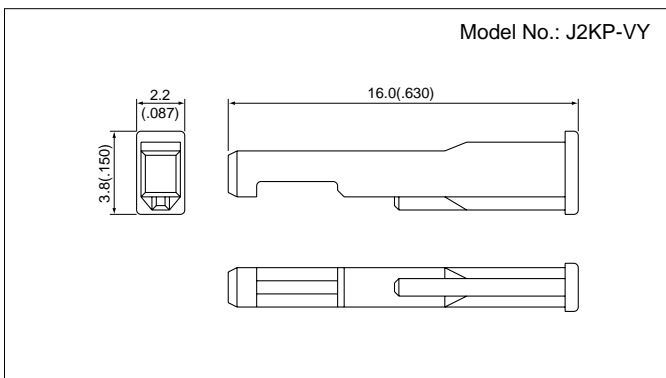

Tab contact cutting tool

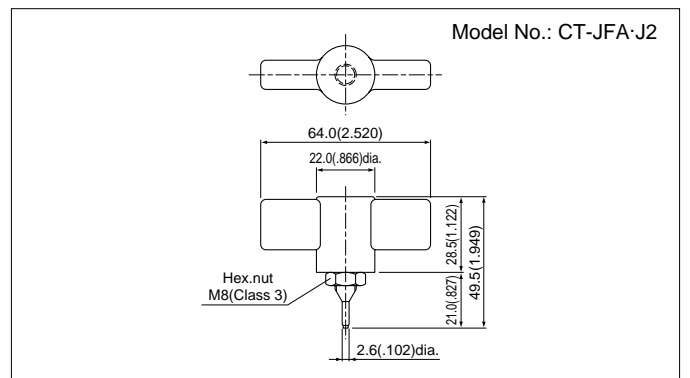

JFA CONNECTOR/J2100

Receptacle housing (Center locking type)

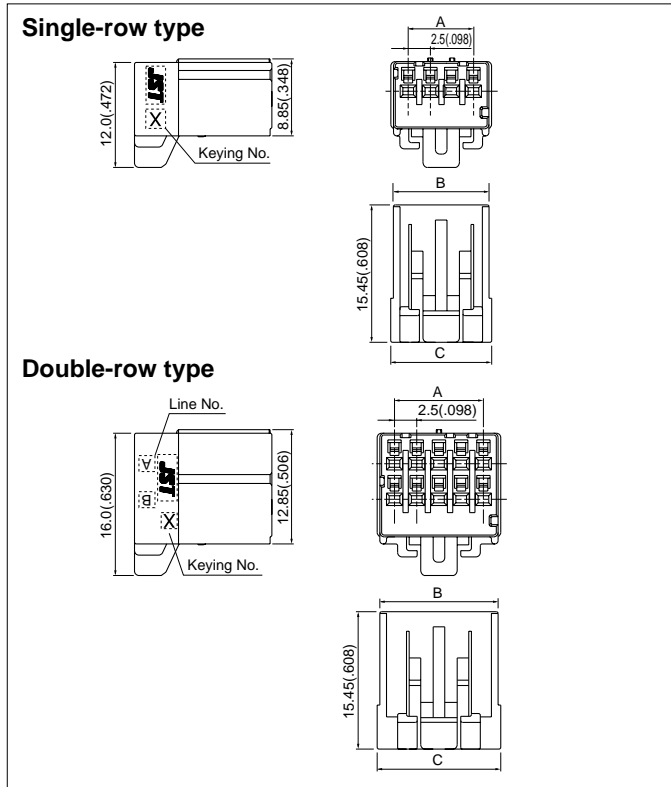

Single-row type

Circuits	Keying	Model No.	Dimensions mm(in.)			Q'ty / box
			A	B	C	
3	X	J21SF-03V-KX	5.0(.197)	8.3(.327)	8.9(.350)	400
	Y	J21SF-03V-KY	5.0(.197)	8.3(.327)	8.9(.350)	400
4	X	J21SF-04V-KX	7.5(.295)	10.8(.425)	11.4(.449)	400
	Y	J21SF-04V-KY	7.5(.295)	10.8(.425)	11.4(.449)	400

Double-row type

Circuits	Keying	Model No.	Dimensions mm(in.)			Q'ty / box
			A	B	C	
6	X	J21DF-06V-KX	5.0(.197)	8.3(.327)	8.9(.350)	300
	Y	J21DF-06V-KY	5.0(.197)	8.3(.327)	8.9(.350)	300
8	X	J21DF-08V-KX	7.5(.295)	10.8(.425)	11.4(.449)	300
	Y	J21DF-08V-KY	7.5(.295)	10.8(.425)	11.4(.449)	300
10	X	J21DF-10V-KX	10.0(.394)	13.3(.524)	13.9(.547)	200
	Y	J21DF-10V-KY	10.0(.394)	13.3(.524)	13.9(.547)	200
12	X	J21DF-12V-KX	12.5(.492)	15.8(.622)	16.4(.646)	200
	Y	J21DF-12V-KY	12.5(.492)	15.8(.622)	16.4(.646)	200
16	X	J21DF-16V-KX	17.5(.689)	20.8(.819)	21.4(.843)	200
	Y	J21DF-16V-KY	17.5(.689)	20.8(.819)	21.4(.843)	200
20	X	J21DF-20V-KX	22.5(.886)	25.8(1.016)	26.4(1.039)	100
	Y	J21DF-20V-KY	22.5(.886)	25.8(1.016)	26.4(1.039)	100

Material

Glass-filled PBT, UL94V-0, black

Tab housing (Panel mounting type)

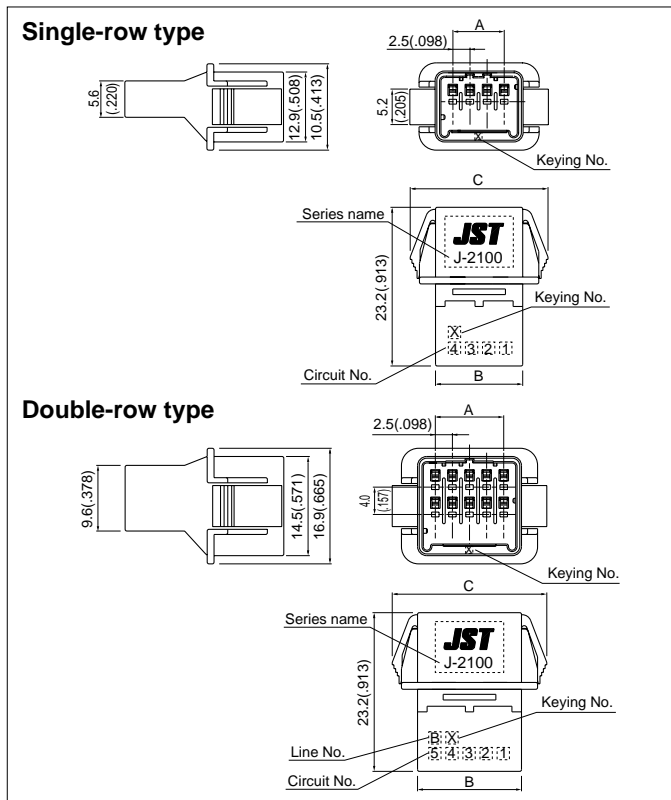

Single-row type

Circuits	Keying	Model No.	Dimensions mm(in.)			Q'ty / box
			A	B	C	
4	X	J21SPM-04V-KX	7.5(.295)	12.7(.500)	20.1(.791)	192
	Y	J21SPM-04V-KY	7.5(.295)	12.7(.500)	20.1(.791)	192

Double-row type

Circuits	Keying	Model No.	Dimensions mm(in.)			Q'ty / box
			A	B	C	
6	X	J21DPM-06V-KX	5.0(.197)	10.2(.402)	17.6(.693)	156
	Y	J21DPM-06V-KY	5.0(.197)	10.2(.402)	17.6(.693)	156
10	X	J21DPM-10V-KX	10.0(.394)	15.2(.598)	22.6(.890)	120
	Y	J21DPM-10V-KY	10.0(.394)	15.2(.598)	22.6(.890)	120
12	X	J21DPM-12V-KX	12.5(.492)	17.7(.697)	25.1(.988)	108
	Y	J21DPM-12V-KY	12.5(.492)	17.7(.697)	25.1(.988)	108
16	X	J21DPM-16V-KX	17.5(.689)	22.7(.894)	30.1(1.185)	84
	Y	J21DPM-16V-KY	17.5(.689)	22.7(.894)	30.1(1.185)	84
20	X	J21DPM-20V-KX	22.5(.886)	27.7(1.091)	35.1(1.382)	72
	Y	J21DPM-20V-KY	22.5(.886)	27.7(1.091)	35.1(1.382)	72

Material

Glass-filled PBT, UL94V-0, black

JFA CONNECTOR/J2100

Panel layout

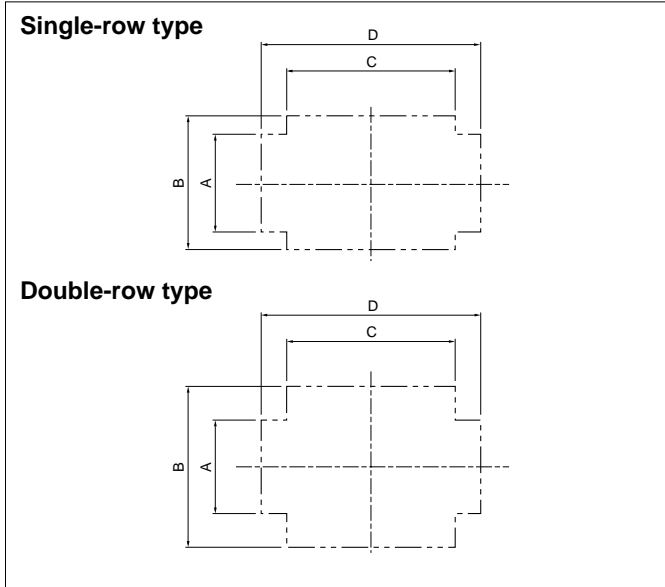

Single-row type

Circuits	Dimensions mm(in.)			
	A	B	C	D
4	7.8(.307)	10.8(.425)	13.0(.512)	17.7(.697)

Double-row type

Circuits	Dimensions mm(in.)			
	A	B	C	D
6	8.6(.339)	14.8(.583)	10.5(.413)	15.2(.598)
10	8.6(.339)	14.8(.583)	15.5(.610)	20.2(.795)
12	8.6(.339)	14.8(.583)	18.0(.709)	22.7(.894)
16	8.6(.339)	14.8(.583)	23.0(.906)	27.7(1.091)
20	8.6(.339)	14.8(.583)	28.0(1.102)	32.7(1.287)

Header top entry type (Center locking type)

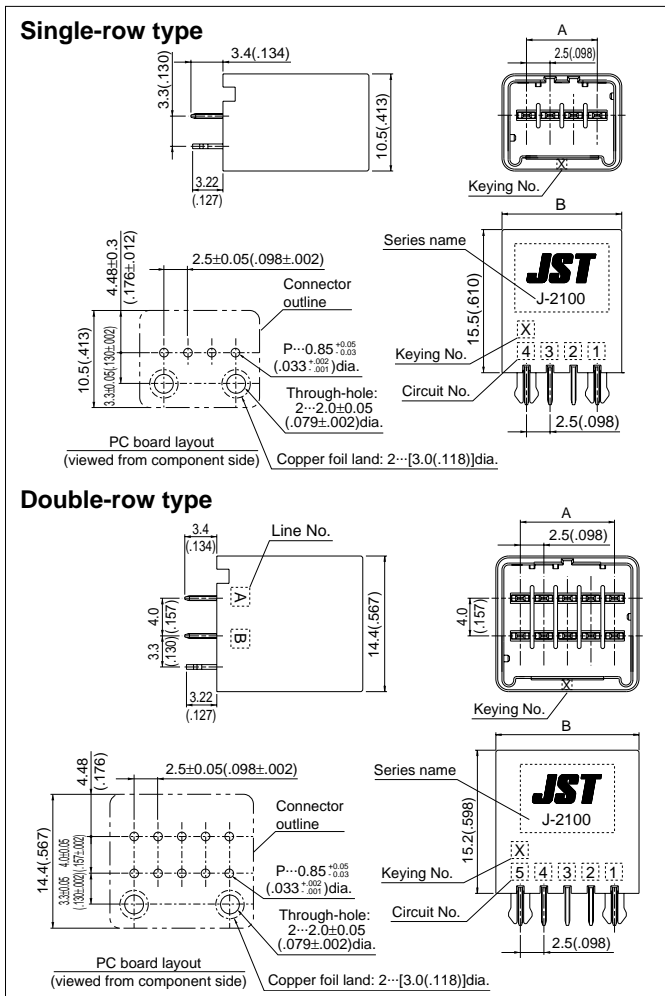

Single-row type

Circuits	Keying	Model No.	Dimensions mm(in.)		Q'ty / box
			A	B	
3	X	B03B-J21SK-GGXR	5.0(.197)	10.2(.402)	378
	Y	B03B-J21SK-GGYR	5.0(.197)	10.2(.402)	378
4	X	B04B-J21SK-GGXR	7.5(.295)	12.7(.500)	306
	Y	B04B-J21SK-GGYR	7.5(.295)	12.7(.500)	306

Material and Finish

Tab contact: Copper alloy, nickel-undercoated, selective gold-plated, selective tin/lead-plated
Housing: Glass-filled PBT, UL94V-0, black
Solder tab: Copper alloy, nickel-undercoated, tin/lead-plated

Double-row type

Circuits	Keying	Model No.	Dimensions mm(in.)		Q'ty / box
			A	B	
6	X	B06B-J21DK-GGXR	5.0(.197)	10.2(.402)	252
	Y	B06B-J21DK-GGYR	5.0(.197)	10.2(.402)	252
8	X	B08B-J21DK-GGXR	7.5(.295)	12.7(.500)	204
	Y	B08B-J21DK-GGYR	7.5(.295)	12.7(.500)	204
10	X	B10B-J21DK-GGXR	10.0(.394)	15.2(.598)	168
	Y	B10B-J21DK-GGYR	10.0(.394)	15.2(.598)	168
12	X	B12B-J21DK-GGXR	12.5(.492)	17.7(.697)	144
	Y	B12B-J21DK-GGYR	12.5(.492)	17.7(.697)	144
16	X	B16B-J21DK-GGXR	17.5(.689)	22.7(.894)	108
	Y	B16B-J21DK-GGYR	17.5(.689)	22.7(.894)	108
20	X	B20B-J21DK-GGXR	22.5(.886)	27.7(1.091)	84
	Y	B20B-J21DK-GGYR	22.5(.886)	27.7(1.091)	84

Material and Finish

Tab contact: Copper alloy, nickel-undercoated, selective gold-plated, selective tin/lead-plated
Housing: Glass-filled PBT, UL94V-0, black
Solder tab: Copper alloy, nickel-undercoated, tin/lead-plated

JFA CONNECTOR/J2100

Header side entry type (Center locking type)

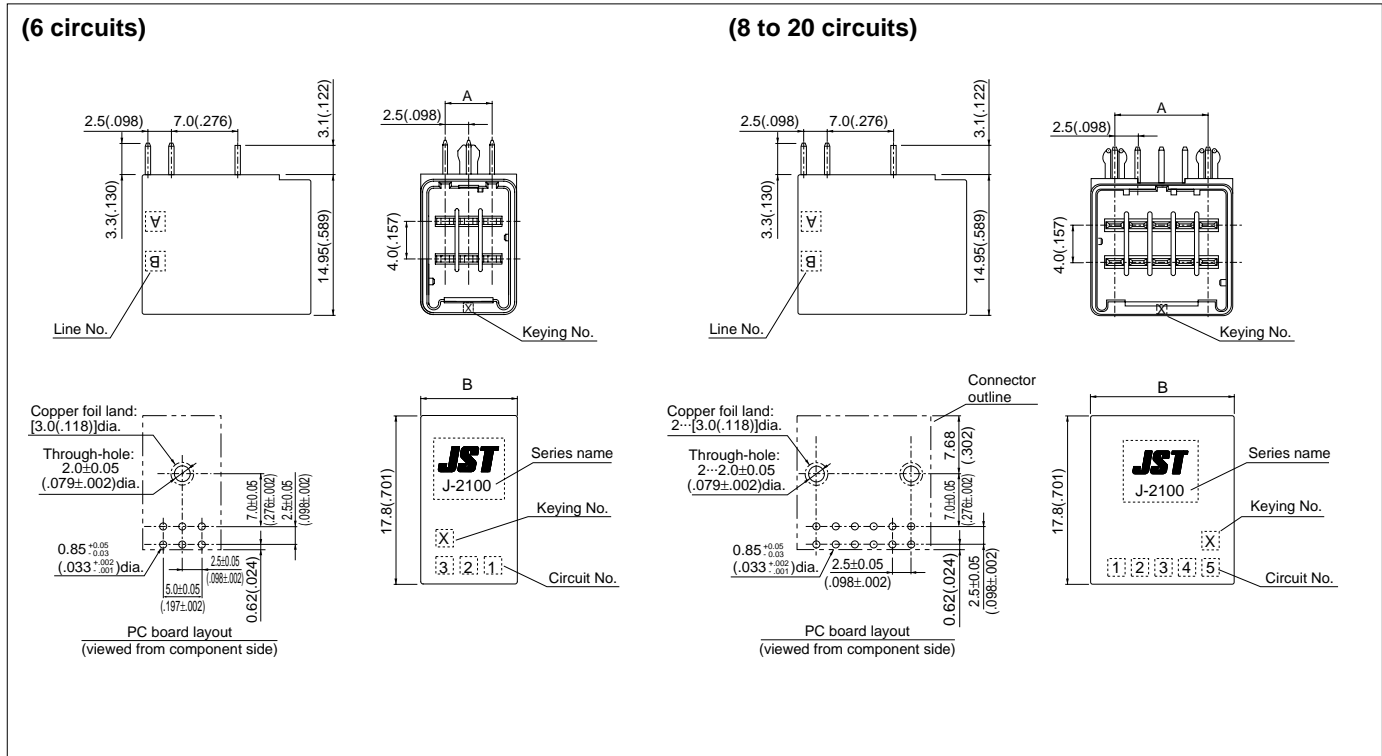

Circuits	Keying	Model No.	Dimensions mm(in.)		Q'ty / box
			A	B	
6	X	S06B-J21DK-GGXR	5.0(.197)	10.2(.402)	252
	Y	S06B-J21DK-GGYR	5.0(.197)	10.2(.402)	252
8	X	S08B-J21DK-GGXR	7.5(.295)	12.7(.500)	204
	Y	S08B-J21DK-GGYR	7.5(.295)	12.7(.500)	204
10	X	S10B-J21DK-GGXR	10.0(.394)	15.2(.598)	168
	Y	S10B-J21DK-GGYR	10.0(.394)	15.2(.598)	168
12	X	S12B-J21DK-GGXR	12.5(.492)	17.7(.697)	144
	Y	S12B-J21DK-GGYR	12.5(.492)	17.7(.697)	144
16	X	S16B-J21DK-GGXR	17.5(.689)	22.7(.894)	108
	Y	S16B-J21DK-GGYR	17.5(.689)	22.7(.894)	108
20	X	S20B-J21DK-GGXR	22.5(.886)	27.7(1.091)	84
	Y	S20B-J21DK-GGYR	22.5(.886)	27.7(1.091)	84

Material and Finish

Tab contact: Copper alloy, nickel-undercoated, selective gold-plated, selective tin/lead-plated
Housing: Glass-filled PBT, UL94V-0, black
Solder tab: Copper alloy, nickel-undercoated, tin/lead-plated

JFA CONNECTOR/J2200

Receptacle housing (Side locking type)

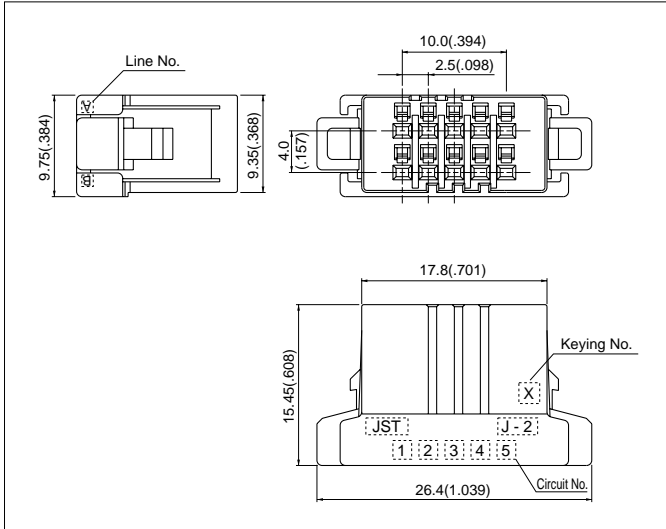

Circuits	Keying	Model No.	Q'ty / bag
10	X	J22DF-10V-KX	250
	Y	J22DF-10V-KY	250

Material			
Glass-filled PBT, UL94V-0, black			

Header side entry type (Side locking type)

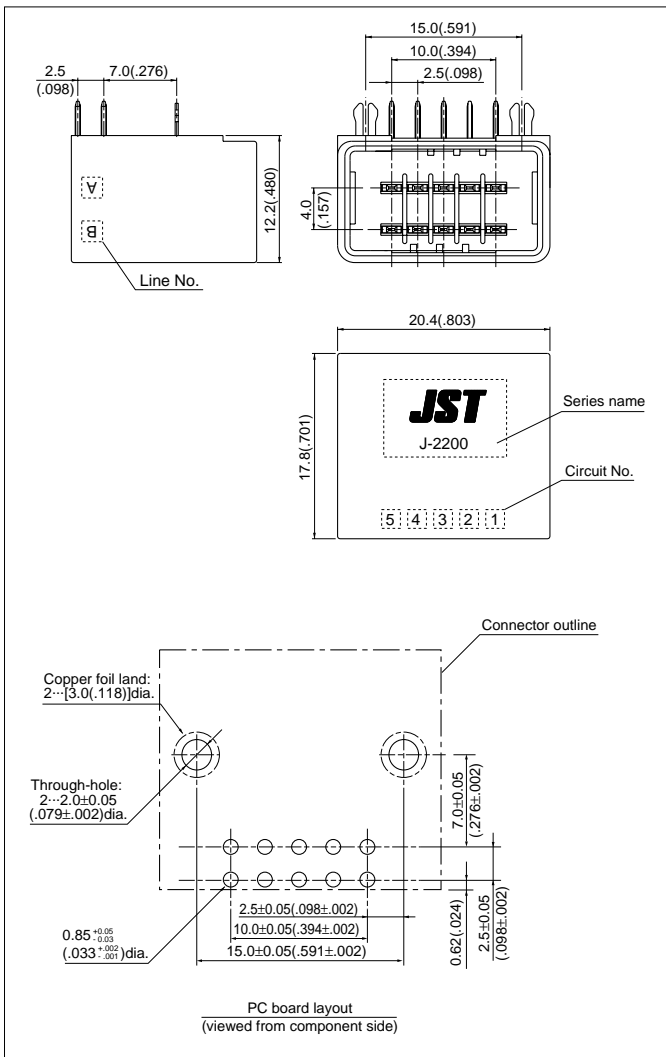

Circuits	Keying	Model No.	Q'ty / box
10	X	S10B-J22DK-GGXR	120
	Y	S10B-J22DK-GGYR	120

Material and Finish			
Tab contact: Copper alloy, nickel-undercoated, selective gold-plated			
Housing: Glass-filled PBT, UL94V-0, black			
Solder tab: Copper alloy, nickel-undercoated, tin/lead-plated			

JFA CONNECTOR/J2500

Receptacle housing (Module type)

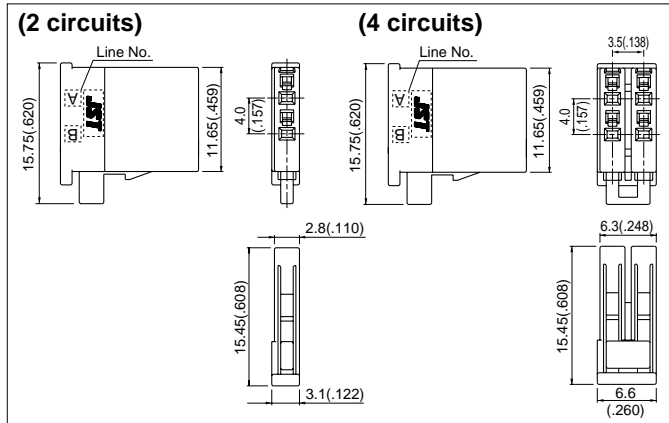

Circuits	Keying	Model No.	Q'ty / bag
2	-	J25MF-02V-K	800
4	-	J25MF-04V-K	400
Material			
Glass-filled PBT, UL94V-0, black			

Header top entry type (Module type)

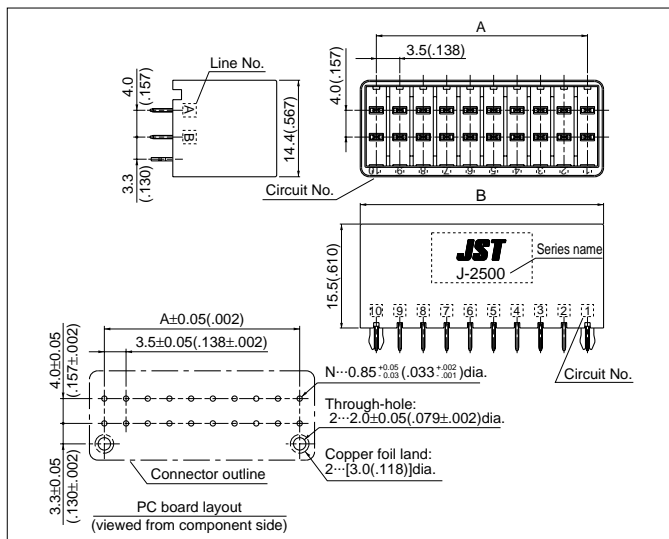

Circuits	Keying	Model No.	Dimensions mm(in.)		Q'ty / box
			A	B	
12	-	B12B-J25DK-GGR	17.5 (.689)	22.3 (.878)	108
20	-	B20B-J25DK-GGR	31.5 (1.240)	36.3 (1.429)	72
Material and Finish					
Tab contact: Copper alloy, nickel-undercoated, selective gold-plated, selective tin/lead-plated					
Housing: Glass-filled PBT, UL94V-0, black					
Solder tab: Copper alloy, nickel-undercoated, tin/lead-plated					

Header side entry type (Module type)

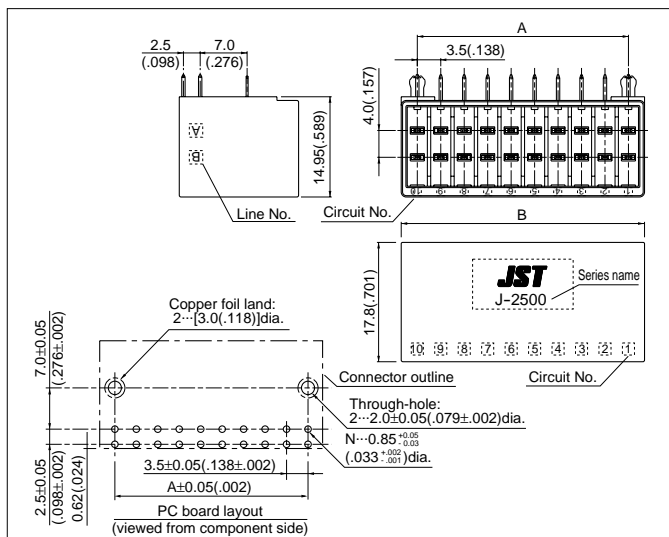

Circuits	Keying	Model No.	Dimensions mm(in.)		Q'ty / box
			A	B	
12	-	S12B-J25DK-GGR	17.5 (.689)	22.3 (.878)	108
20	-	S20B-J25DK-GGR	31.5 (1.240)	36.3 (1.429)	72
Material and Finish					
Tab contact: Copper alloy, nickel-undercoated, selective gold-plated, selective tin/lead-plated					
Housing: Glass-filled PBT, UL94V-0, black					
Solder tab: Copper alloy, nickel-undercoated, tin/lead-plated					

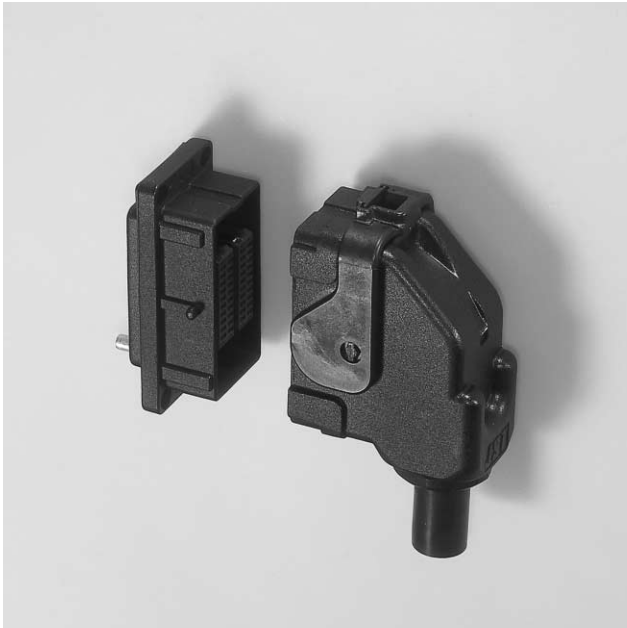

This connector is a metal shell type I/O connector with completely waterproof. Contacts are designed to be common with JFA connector J2000 series. The long tab contact realizes sequential circuit construction.

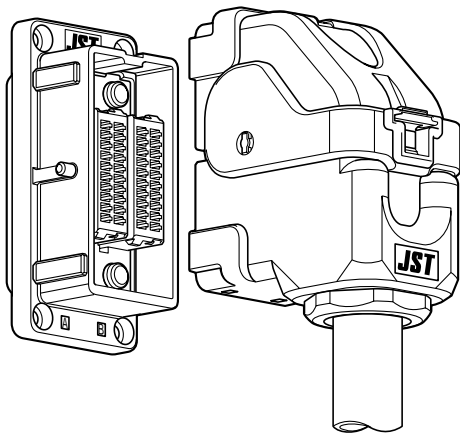

Features

• **Rigid metal shell**

Aluminum die-casting shell prevents from influence of external force. High waterproof performance as 7 ingress protection of JIS C 0920.

• **Easy mating operation**

Plug, cap and assembly have temporary retention features, and connector mating is completed by light rotating operation of lock lever. Lock lever is fixed when mated, and it prevents lock from coming off due to vibration and so on.

• **Long type tab contact**

Both standard type and long type tab contact are available as a tab contact.

The long type tab contact realizes sequential circuit construction.

Specifications

- Current rating: 3A max. AC, DC
- Voltage rating: 250V AC, DC
- Temperature range: -55°C to +105°C
(including temperature rise in applying electrical current)
- Withstanding voltage: 1,500V AC/minute
- Applicable wire: AWG #28 to #20
- Cable O.D.: 11.1 to 13.5mm (.437" to .531")
- * Contact JST if Lead-Free product is required.
- * Refer to "General Instruction and Notice when using Terminals and Connectors" at the end of this catalog.
- * Contact JST for details.

JFA CONNECTOR/J2900

Wire side Shell kit

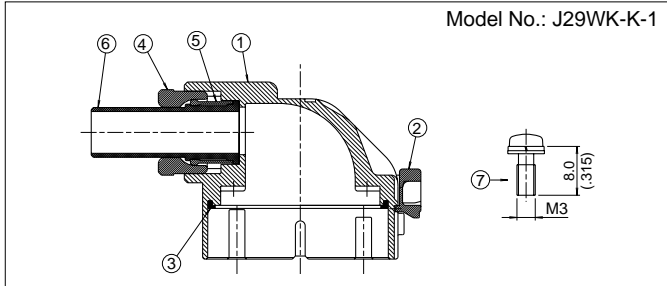

No.	Parts name	Q'ty
1	Shell at wire side	1
2	Lever	1
3	Seal ring	1
4	Clamp nut	1
5	Clamp arm	1
6	Clamp rubber	1
7	Sems screw(M3X8L)	4

Tab housing assembly

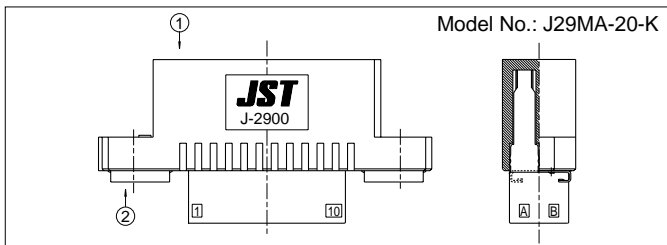

No.	Parts name	Q'ty
1	Tab housing	1
2	Ground contact B	2

Note: Refer to page 139 about tab contact.

Panel side Shell kit

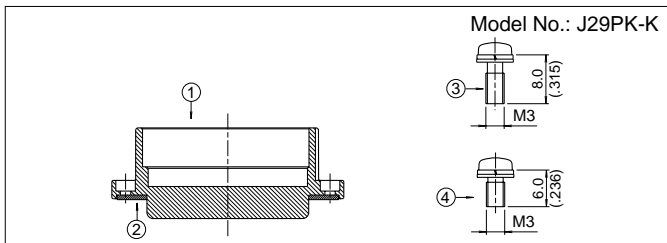

No.	Parts name	Q'ty
1	Shell at panel side	1
2	Seal rubber plate	1
3	Sems screw(M3X8L)	4
4	Sems screw(M3X6L)	1

Receptacle housing assembly

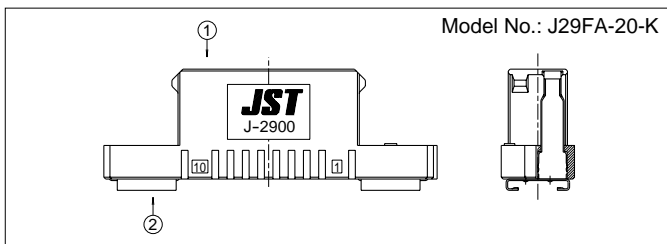

No.	Parts name	Q'ty
1	Receptacle housing	1
2	Ground contact B	2

Note: Refer to page 139 about receptacle contact.

Ground terminal

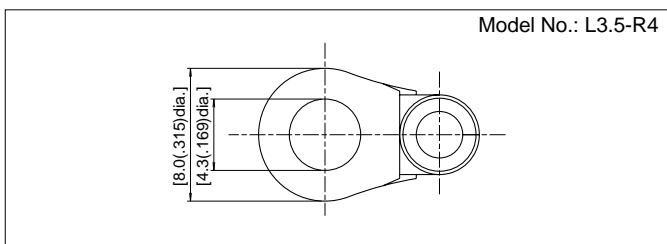

JFA CONNECTOR/J2000/J2100/J2200/J2500/J2900 & J2000 SERIES PROTECTOR

Applicator for the semi-automatic press AP-K2N

Contact	Crimp applicator MKS-L		Compact crimp applicator MKS-LS		Strip-crimp applicator MKS-SC
	with safety cover	without safety cover	with safety cover	without safety cover	with safety cover
SJ2F-002GF-P1.0	APLMK SJ2F/M002-10	APLNC SJ2F/M002-10	-	-	-
SJ2M-002GF-M1.0N	APLMK SJ2F/M002-10	APLNC SJ2F/M002-10	-	-	-
SJ2F-01GF-P1.0	APLMK SJ2F/M01-10	APLNC SJ2F/M01-10	-	-	-
SJ2M-01GF-M1.0N	APLMK SJ2F/M01-10	APLNC SJ2F/M01-10	-	-	-
SJ2M-01GF-M1.0S	APLMK SJ2F/M01-10	APLNC SJ2F/M01-10	-	-	-
SJ2F-21GF-P1.0	APLMK SJ2F/M21-10	APLNC SJ2F/M21-10	-	-	-
SJ2M-21GF-M1.0N	APLMK SJ2F/M21-10	APLNC SJ2F/M21-10	-	-	-

JFA CONNECTOR J2000 SERIES PROTECTOR

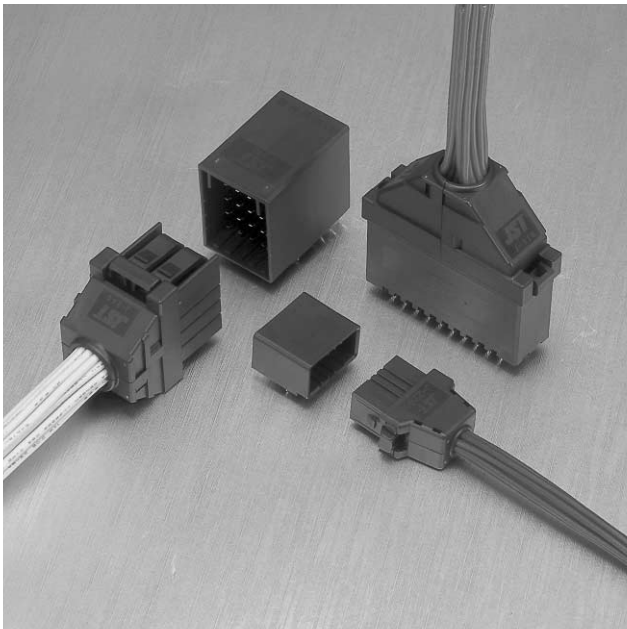

When applying current to connector, this protector prevents insertion of foreign matter to contacting part from wire side. But it does not have function of wire retention.

J2100 series for 6 and 8 circuits

Model No. of ① J21PF-06SCA
6 circuits ② J21PF-06SCB

Model No. of ① J21PF-08SCA
8 circuits ② J21PF-08SCB

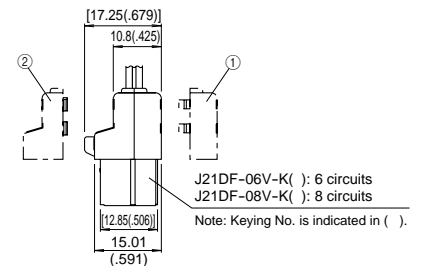
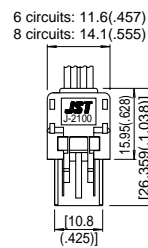

J2200 series for 10 circuits

Model No. ① J22PF-10VK

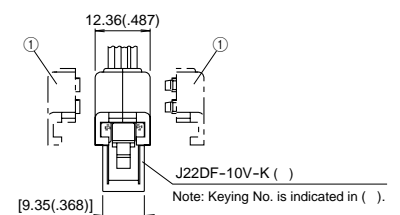
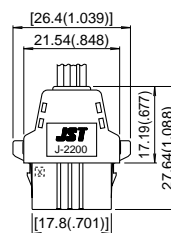

Note: Protector is not UL approved.